

2015 Educational Outreach

Directed Energy is Here Today!

High Power Microwaves
High Power Radio Frequency
Support Systems

High Power Lasers
Optical Technology



**The United States Leads the World in
Directed Energy Technology**



DE2DC

Directed Energy to the District of Columbia 2015 Educational Exhibits

**EVENING Reception and Poster Session
April 28th - 1630-1900 - Rayburn building**

**Pentagon Exhibit of DE Hardware
April 29th - 0900-1300 - Pentagon Courtyard**

**Congressional Exhibit of DE Technology
April 30th - 1100-1400 - Rayburn Building Atrium**

DIRECTED ENERGY OUTREACH CAMPAIGN

II-VI OPTICAL SYSTEMS



BAE SYSTEMS



Defense Systems
Information Analysis Center



NORTHROP GRUMMAN

Booz | Allen | Hamilton

Brashear



delivering results that endure

PARSONS



Sandia
National
Laboratories



The Directed Energy Professional Society (DEPS) was founded in 1999 to foster research and development of Directed Energy (DE) technology for national defense and civil applications, through professional communication and education. We intend to be recognized as the premier organization for exchanging information about and advocating research, development and application of Directed Energy.



Through an educational grant sponsored by the High Energy Laser Joint Technology Office, DEPS is able to affect the Directed Energy community with graduate scholarships, summer internships at government laboratories, service academy projects, textbook and journal publications, development & presentation of professional education short courses, and hosting of professional conferences/workshops.

The *Journal of Directed Energy* is a peer-reviewed publication of the Directed Energy Professional Society. It addresses the many aspects of fully engineered directed energy (DE) systems and advances DEPS vision of becoming the premier institution for the exchange of DE information. *The Journal* is made possible by grants from the High Energy Laser Joint Technology Office and by funding from DEPS.

The *Journal of Directed Energy* provides a central source for the dissemination and exchange of timely information on the various aspects of DE. It provides a forum for the collegial interaction necessary for the testing of ideas and for identifying new opportunities and directions for the advancement of the field. Although other forums exist for publishing archival papers in the various fields associated with DE, *The Journal* is distinguished by its focus on the emerging DE engineering and system issues, and by its willingness to publish classified papers.





L-3 High Energy Laser Systems

L-3 Brashear designs and produces complex electro-optical and electro-mechanical systems for the defense, aerospace and commercial markets. For decades our military tracking and range instrumentation systems have served as benchmarks for performance. The same exceptional quality, ruggedness and reliability have been proven in our precision, high energy, laser beam director systems. L-3 Brashear is proud to support today's warfighters with integrated technologies and systems that deliver multi-layer protection as they locate, discriminate and eliminate threats around the globe.

With more than 20 years of laser systems experience, L-3 Brashear systems and components have been validated in airborne, desert and maritime environments.

L-3 Brashear's critical knowledge and manufacturing skills have been chosen by all of the U.S. High Energy Laser/Directed Energy (HEL/DE) weapons prime contractors and U.S. government agencies for high energy laser weapon programs.

Combining high agility with extremely low tracking jitter, L-3 Brashear integrated systems not only provide exceptional accuracy, but are durable enough to meet the demands of field mobility and extreme environmental conditions.

L-3 high energy laser systems have taken scientists out of the loop making HEL systems

operable by warfighters and ready for use on the battlefield. You will find L-3 Brashear technology in:

- Navy Laser Weapon System (LaWS)
First deployed and soldier operated HEL system
- Solid-State Laser Technology Maturation (SSL-TM)
- Ground Based Air Defense (GBAD)
- Maritime Laser Demonstration (MLD)
- Lightweight Beam Director (LWBD)
- Tactical High Energy Laser (THEL)
- Airborne Laser (ABL)
- Advanced Tactical Laser (ATL)
- High Energy Laser Technology Demonstrator (HELTD)

THE PREMIER PROVIDER OF HIGH ENERGY LASER CONTROL SYSTEMS AND COMPONENTS:

- Beam Directors
- Stabilized Gimbals
- Ruggedized optical systems
- Beam expander telescopes
- Fast steering mirrors

SETTING NEW BENCHMARKS IN:

- Integrated control systems
- Kilowatt - megawatt power class
- Fast, precision pointing/tracking
- Stable, low-jitter tracking
- High Energy Laser (HEL) optics
- Beam stabilization
- Sensor integration
- EMI/RFI hardened

Brashear

Tel: 412.967.7700

Email: Sales.IOS@L-3com.com

www.L-3com.com/IOS





High Energy Laser Joint Technology Office

Establishing the Foundation for Laser Weapon Systems

The High Energy Laser Joint Technology Office (HEL-JTO) manages a portfolio of science and technology projects in Directed Energy (DE) spanning Academia, Government, and Industry. In addition to advancing the state of the art in High Energy Lasers for military applications, the JTO established an Educational Outreach program to address the issue of limited numbers of US students trained in the various HEL disciplines. This Educational Initiative prepares selected students with the skills necessary for a career in HEL, and encourages them to join the HEL workforce after graduation. Support is also provided to technical faculties at the Service Academies to encourage and enable Cadet Research in relevant HEL areas.



Training the future HEL workforce



Advocates HEL development & transition

Addresses joint technology requirements

Stimulates inter-service research

Orchestrates portfolio of R&D projects across government/industry/academia

Establishes community standards & tools

Educates next generation of HEL technical, policy, & program leaders

The JTO utilizes a multi-pronged approach to advance HEL technologies through basic and exploratory research, working with Universities, DoD Services & Agencies (S&A), and Industry. Subject matter experts, as members of Technical Area Working Groups, representing DoD organizations, advocate DE interests of their respective Service or Agency, to the JTO to determine the priority of the specific topics to be investigated.



Graduate students at the University of New Mexico

Multi-Disciplinary Research Initiatives (MRI) support basic research activities at Universities to conceive, explore, and incubate, high risk / high pay-off ideas to improve HEL performance. MRI teams, graduate & undergraduate students, gain research experience in HEL technology while pursuing their academic degrees.

Research topics are selected to complement / advance technologies to meet S&A program goals and to further the objectives of these programs, and to keep government laboratory research personnel current on technical developments.

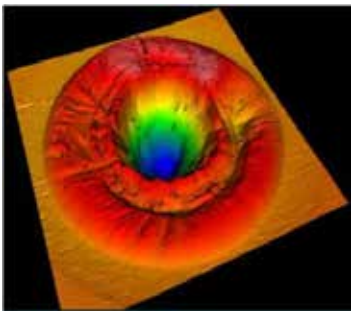

Modeling the effects of HEL on materials at Pennsylvania State University

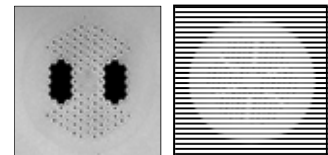

Gain tailored photonic crystal fiber development at Air Force Research Laboratory

Cladding-pumped Raman gain fibers developed at the Army Research Laboratory



Advanced HEL Deformable Mirror

Industry responses to Broad Area Announcements have invariably been excellent; contracts are structured to advance the success of multi-Service DE programs. The DE technical base has grown due to JTO sponsorship with significant technical contributions and development of commercialized products by a number of businesses.



2x2 VCSEL Array
2.7x2.7mm / 530W power



JHPSSL developed by Northrup Grumman

Scientific investigations, in a multitude of high energy laser technologies, have resulted in a number of record breaking achievements. Advancements in solid-state laser technology, prompted the Joint High Power Solid State Laser (JHPSSL) program, directed and managed by the JTO, with the participation and support of the military Services. The JHPSSL program culminated in the first demonstration of a solid-state laser with power output above 100 kW.

Building on this success, the JTO initiated a program to increase laser efficiency and to start addressing “field-ability” of laser devices, the Robust Electric Laser Initiative (RELI). The RELI development program is exploring multiple technologies to achieve improved performance.

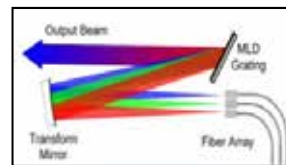

Lockheed Martin's Robust Electric Laser Initiative program uses spectral beam combining.

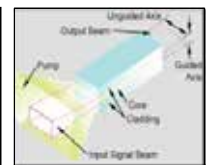

Raytheon's Robust Electric Laser Initiative (RELI) program utilizes Planar Waveguide architecture.

Both slab-based and fiber combined laser concepts have made significant progress, achieving output power and efficiency goals in demonstrations with very good laser beam quality. Services are incorporating RELI developments into their Directed Energy programs. Army chose a fiber-based laser concept as the basis for their HEL Mobile Demonstrator (HEL- MD) Program, the Marine Corps selected a slab-based RELI laser for their Ground Based Air Defense (GBAD) Program, the Navy deployed a fiber-based system, and Air Force is pursuing a fiber laser concept.

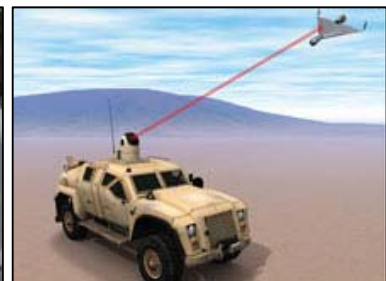

With the demonstrated improvements in solid-state laser devices, achieving power goals, exhibiting excellent laser beam quality, increasing efficiency, and progressing toward desired weight and volume necessary for integration onto a military platform, the JTO is concentrating its emphasis on another major part of a laser weapon system, the management and control of the laser beam. This initiative, Advanced Beam control for Locating and Engagement (ABLE) will improve the overall performance of the laser beam control system. The emphasis of the ABLE system is to: 1) maximize the laser throughput; 2) enhance pointing and tracking capabilities; and 3) advance atmospheric compensation through turbulent environments. State of the art components in these areas are being developed for subsystem capability demonstrations. Ultimately, an integrated system demonstration, with a RELI-class laser will be employed to demonstrate the system performance improvements provided by ABLE technologies.

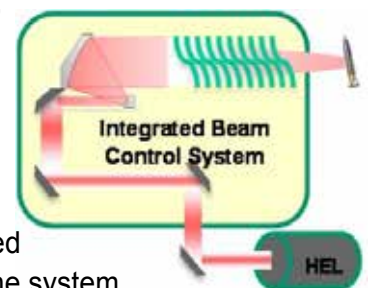



Maritime Laser Weapon Systems

Proven, capable, affordable



THE VALUE OF PERFORMANCE.

NORTHROP GRUMMAN

Maritime Laser Weapon Systems

Naval Defense at the Speed of Light

Current and advanced threats create increasing operational challenges for the U.S. Navy and conventional defense systems. Traditional and irregular warfare threats – including swarming small boats, UAVs, enemy aircraft and anti-ship cruise missiles – are proliferating and growing more difficult to detect, track, engage, disable or destroy.

To counter these threats, the fleet requires affordable countermeasures with operational flexibility and military superiority. Northrop Grumman high-energy laser systems have demonstrated their speed-of-light weapons capabilities and can provide the solutions warfighters need.

Maritime Laser Weapon System

The Maritime Laser Weapon Systems (MLWS) concept leverages solid state laser technology from years of research and proven laboratory demonstrations to create a near-term operational laser weapon with substantial payoff for the warfighter.

Northrop Grumman's solid state laser architecture allows for power levels scaling to the 100 kilowatt class, preserving good beam quality to defend ships from a wide variety of threats.

MLWS is a cost-effective weapon when compared with more traditional munitions, providing the combatant commander the option of using a low-cost-per-engagement laser weapon instead of expensive missiles with limited magazine against low-value targets.

Additionally, high resolution images provided by the stabilized, optical pointing and tracking system yield an extremely effective, multi-mission capability for situational awareness and intelligence, surveillance and reconnaissance missions at long ranges.

Northrop Grumman's recent record-breaking performance of concurrent electric laser power levels, beam quality, and run-time, combined with new compact, modular and rugged designs, solidify the technological readiness of solid-state laser weapons. With low cost per shot, deep magazine, and ultra-precision, Northrop Grumman high-energy lasers will help the U.S. Navy address current and future threats.



Laser weapon ship integration analyses have been performed to determine potential beam director and subsystem locations for DDG 51.



MLWS can be configured to defend against anti-ship missiles providing an ultra-precise, low cost-per-shot solution for U.S. Navy threats.

**Northrop Grumman Laser Systems:
Defense at the Speed of Light**

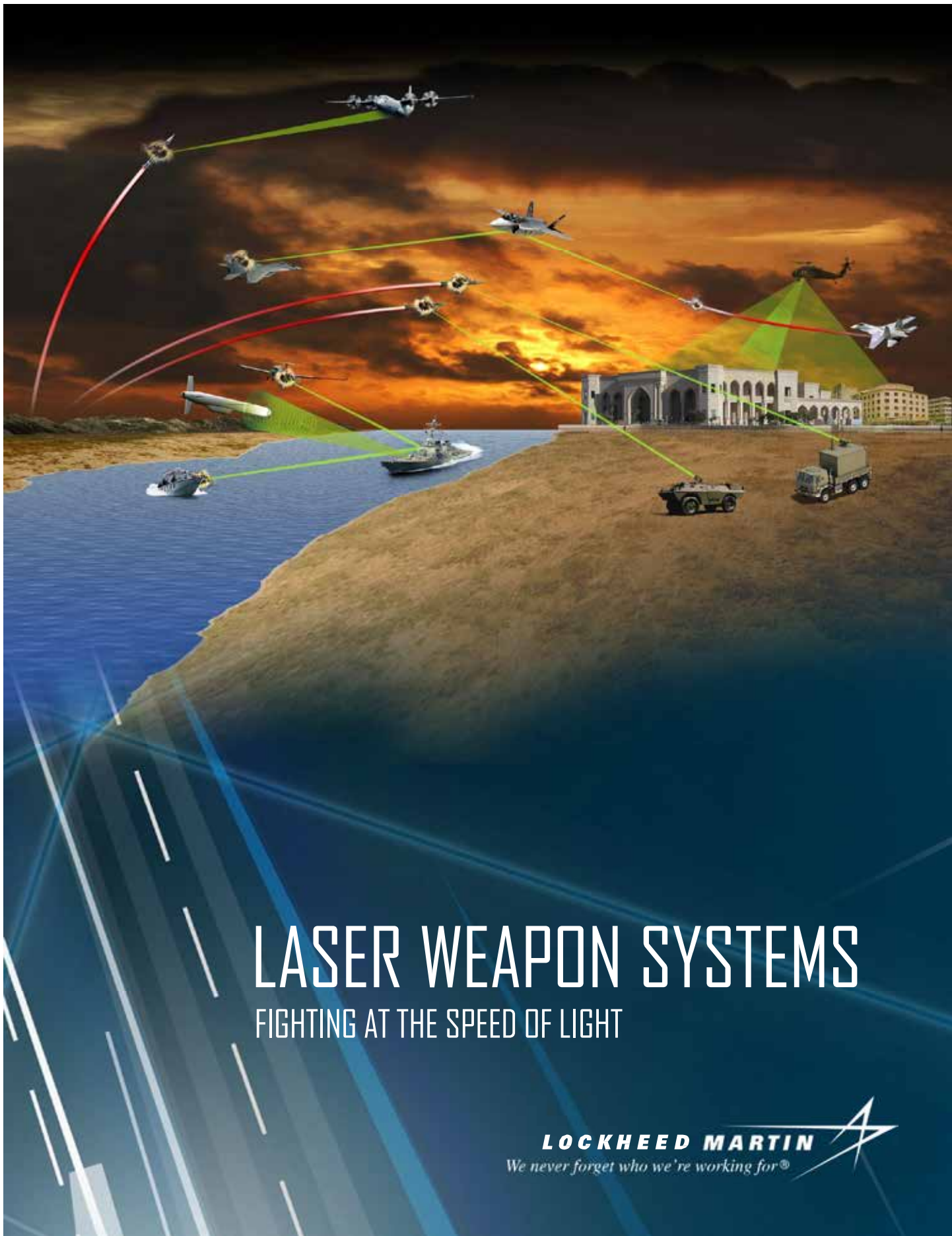

LASER WEAPON SYSTEMS

FIGHTING AT THE SPEED OF LIGHT

LOCKHEED MARTIN
We never forget who we're working for.®



COMBINING HIGH QUALITY WITH GREATER EFFICIENCY



ADAM – Area Defense Anti-Munitions

- Autonomous operations for rocket threats; accepts external sensor cue when required; capable of continuous operation
- Successfully engaged constrained and free-flying rockets, an unmanned aircraft systems (UAS) target in flight, and a small boat
- Affordable commercial-off-the-shelf (COTS) based system with very low cost-per-kill; deep magazine; scalable; precision effects
- Capable of close-in defense (1-4 km)



ALADIN - Accelerated Laser Demonstration Initiative

- 30-kilowatt laser made by combining many fiber lasers into a single, near-perfect-quality beam of light
- Uses approximately 50 percent less electricity than alternative solid-state laser technologies
- Spectral Beam Combining sends beams from multiple fiber laser modules, each with a unique wavelength, into a combiner that forms a single, powerful, high-quality beam



ATHENA I - Advanced Test High Energy Asset

- Represents highest power level documented by a laser weapon system of this type, while retaining excellent beam quality and electrical efficiency
- First field testing of an integrated 30-kilowatt single-mode fiber laser weapon system prototype
- Uses the proven high-energy laser weapon system architecture from our ADAM system, and incorporates the 30-kilowatt ALADIN laser



High Energy Laser Mobile Demonstrator (HEL MD)

The High Energy Laser Mobile Demonstrator (HEL MD) is a mobile, solid-state, truck-mounted laser system designed to provide speed of light, ultra-precision capability for counter rocket, artillery and mortar (C-RAM) and unmanned aerial system (C-UAS) threat defense. Boeing and the U.S. Army have proven HEL MD's capability to effectively acquire, track and destroy mortars and unmanned aerial vehicles (UAVs) using a 10kW solid-state laser. HEL MD harnesses the power of directed energy to strengthen and protect the warfighter.



Maritime Laser Systems

Laser technology is a game-changing capability for naval forces. It provides scalable, lethal or non-lethal effects against myriad targets such as small boat threats and airborne vehicles. Laser technology also enhances Intelligence, Surveillance, and Reconnaissance (ISR) capabilities, providing earlier identification and tracking of targets. Boeing is developing a beam control system that enables solid-state laser technology to defend against swarm boat and unmanned aerial vehicle (UAV) attacks. Boeing has worked extensively with the US Navy to leverage megawatt-class laser technology for defense against surface, air, anti-ship cruise missile and ballistic missile threats.



Phantom Eye

Phantom Eye is a hydrogen-fueled, high altitude, long endurance unmanned aerial vehicle (UAV) that will be capable of seven days of endurance at 65,000 feet with 2,000 pounds of payload weight. Phantom Eye makes sensing from the stratosphere accessible and affordable with global reach from a single base. Phantom Eye provides the warfighter with transformational and persistent sensing, surveillance and communications capabilities.





3-D LIDAR System

Boeing's 3-D LIDAR system is designed for military and commercial applications ranging from foliage penetration to tracking satellites. This lightweight, compact system couples a camera with a low-power laser to measure objects in three dimensions. This translates to extremely precise imaging, which provides the warfighter with critical information prior to going into a hazardous situation. The integrated payload, which weighs less than 20 pounds, can be optimized for a variety of missions including ground mapping, target tracking, target identification, foliage penetration and aimpoint determination. These missions can be accomplished from a variety of air, ground, or sea platforms.

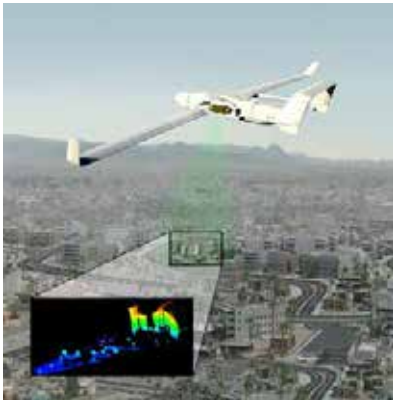

Compact Laser Weapon System

Boeing's Compact Laser Weapon System employs a rugged, 2-kilowatt fiber laser that is ideal for tactical missions. Its lightweight, compact design can be easily transported or mounted on a vehicle or other platform.



For further information, contact:
Denise Hollywood
703-414-6042
denise.m.hollywood@boeing.com

II-VI Optical Systems capabilities and expertise were used to support the ABL HEL DE Weapon System. New capabilities that have been developed related to Sapphire Window manufacturing, Conformal Windows, SiC materials and coatings provide II-VI OS with the expertise required to support future HEL DE Weapon Systems.

ABL Beam Diagnostics: Low Power Optical Train (LPOT)

II-VI Optical Systems provided all of the optics, sensors integrated on the optical bench supporting LPOT

Low Power Optical Train

Low power beam sampled by Beam Reduction Assembly
Airborne, Vacuum Environment
Laser Reference Sources

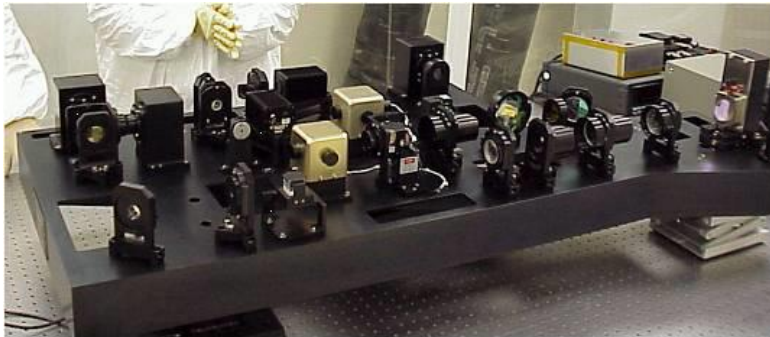

Integrated Bench Assembly

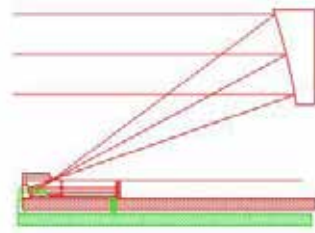

Beam Reduction Assembly

System performs functional beam diagnostics that are fed back to the main beam control system, these include:

- Total Power
- Polarization
- Wave Front Error
- Power Distribution
- Beam Tilt
- Beam Decenter

Provides μ radian Accuracy & Sub- μ radian stability

Pre-aligned on bench and transported to A/C for installation in the Mid-Optical Bench



II-VI Optical Systems – Murrieta and Tustin CA, New Port Richey FL

www.opticalsystems.com

DEFENSE SYSTEMS INFORMATION ANALYSIS CENTER



DIRECTED ENERGY WEAPONS

HIGH POWER MICROWAVE

MODELING & SIMULATION

HIGH ENERGY LASER

NON-LETHAL WEAPONS

ADVANCED MATERIALS



U.S. Navy



U.S. Missile Defense Agency



U.S. Marine Corps

**FREE
TECHNICAL
INQUIRY
SERVICE**

DSIAC SUPPORTS THE DIRECTED ENERGY COMMUNITY

The DSIAC is the latest evolution in the Department of Defense Information Analysis Center (DoD IAC) Enterprise. Through our access to vast repositories of Scientific and Technical Information (STI) and our network of subject matter experts, DSIAC helps the DoD, U.S. Government agencies, academia, industry, and other Directed Energy stakeholders to develop, evaluate, and document technical solutions. DSIAC staff are ready and available to:

- Perform tailored literature searches, fulfill technical document requests, research and answer technical questions, and provide expert referrals. Technical inquiry service is provided free of charge with a duration limit of 4-hours.
- Collect, analyze, organize, and disseminate Defense Systems STI to qualified clients.
- Foster and support the Directed Energy Community of Practice.

- Publish the quarterly *DSIAC Journal*, which is available electronically at the DSIAC web site or in print upon request.
- Develop, manage, and/or distribute controlled access tools, databases, and models for the Defense Systems community.

Additionally, the Core Analysis Task delivery order vehicle is available for DSIAC to perform specialized work under our pre-competed IDIQ contract. Contact the DSIAC for details.



“Transforming Information into Knowledge”

4695 Millennium Drive, Belcamp, MD 21017-1505
443-360-4600 | www.dsiac.org



Sandia Labs – on the leading edge of DE Research

Sandia is a multidisciplinary national laboratory and federally funded research and development center (FFRDC) for the National Nuclear Security Administration. Sandia accomplishes tasks integral to the mission and operations of our sponsoring agencies by

- Anticipating and resolving emerging national security challenges
- Innovating & discovering new technologies to strengthen the nation’s technological superiority
- Creating value through products and services that solve important national security challenges
- Supporting “Strategic Partnership Projects” via contracts and cooperative research agreements

Sandia National Laboratories is a world leader in pulsed power science and technology. Sandia has decades of experience in directed energy research for National Security with expertise in Compact Pulsed Power System Design, High Power Electromagnetics, Modeling and Simulation, Semiconductor RF/Optoelectronic and Microelectronic Circuit Design, Effects Testing, Laser Applications, Materials Development and Characterization, Microsystems & Engineering Sciences Applications, and Sensor & Systems Exploitation.

Important Accomplishments in 2014 **Electronic Battle Damage Assessment**

- *Techniques to detect system changes based upon electromagnetic emissions.*
- *Developed a fieldable software defined radio based data acquisition system.*
- *Developed localization techniques for complex environments.*
- *Demonstrated eBDA for several national security programs.*

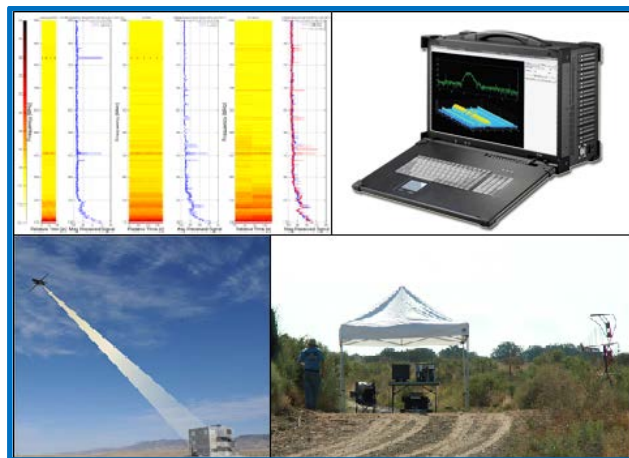

HPM Susceptibility of Graphene Devices

- *1st of its kind comparative study on HPM induced effects in graphene field effect devices (GFETs).*
- *Calibrated survivability of GFETs against known silicon device structures.*
- *Results suggest that graphene could enable robust applications.*

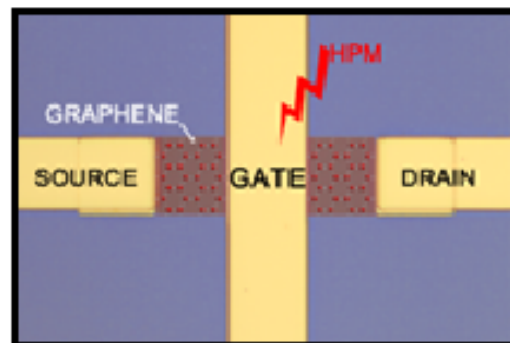



DoD Non-Lethal Weapons Program

Directed Energy Initiatives

The Defense Innovation Initiative is a Department-wide effort to identify and invest in innovative ways to sustain and advance America's military dominance for the 21st century. Some of the Department's most innovative research is being conducted by the DoD Non-Lethal Weapons (NLW) Program.

The DoD NLW Program stimulates and coordinates non-lethal weapons requirements of the U.S. Armed Services and allocates resources to help meet these requirements. The Commandant of the Marine Corps serves as the DoD NLW Program's Executive Agent.

The DoD NLW Program is evaluating candidate directed energy to identify new capabilities to deliver non-lethal effects to targets. Future non-lethal systems will use advanced directed energy technologies to safely deter individuals whose intent is unclear, or to stop suspicious vehicles or vessels with minimum risk of harm to occupants.

Low-energy dazzling lasers such as the LA-9/P and the GLARE MOUT 532-M, have been fielded by the U.S. Marine Corps. Both lasers provide Marines non-lethal capabilities to communicate discrete, non-verbal hailing and warning signals to individuals while on patrol, convoys, and at entry control points and check points.



The LA-9/P low-energy dazzling laser is currently used by the U.S. Marine Corps, U.S. Navy and U.S. Coast Guard.

Advancement in laser safety and effectiveness is ongoing as the Marine Corps is currently developing the **Ocular Interruption Device**, which will incorporate controls to reduce the risk of unintended lasing by automatically regulating unintended exposure to the laser.

High-power microwaves are showing promise as a means to non-lethally stop vehicles and vessels—without harming the occupants. The **Radio-Frequency Vehicle Stopper** in concept development is designed to stop vehicles. By allowing a safe and non-lethal “keep out zone” the RFVS has the potential to support multiple missions including force protection, checkpoints, access control point, roadblocks and mounted patrols.



DoD Non-Lethal Capabilities: Enhancing Readiness For Crisis Response



Active Denial Technology integrated onto a U.S. Marine Corps tactical vehicle.

Also on the forefront is the **Radio-Frequency Vessel Stopper**, which is designed to stop or disable vessels. This technology has the potential to support multiple missions including force protection, port security operations and vessel pursuit/stop/interdiction.

There are also operational non-lethal applications with 95 GHz millimeter-wave technology. **Active Denial Technology (ADT)** projects a focused beam of millimeter waves to induce an intolerable heating sensation on an adversary's skin, repelling the individual with minimal risk of injury. The DoD initially demonstrated ADT using long-range (1,000 m), large spot-size (1.5 m) systems.



Service members are briefed about Solid-State Active Denial Technology (prototype on trailer) at Joint Base Lewis-McChord, WA. The Active Denial System 2, located behind SS-ADT, was also on hand for a military utility assessment during 2014.

The DoD NLW Program and the U.S. Army's Research Development and Engineering Command (RDECOM) Armament, Research, Development and Engineering Center (ARDEC) have been collaborating on a next generation active denial capability that will use solid state technology and yield a smaller, lighter system with a shorter range (~100 m) and smaller spot size (~0.5 m).

Solid-State Active Denial Technology (SS-ADT)

(above) uses a gallium nitride semiconductor energy source to produce 95 GHz millimeter waves, as part of a stand-alone "adjunct" system that can be integrated onto new or existing platforms. In FY14, the solid state skid-plate demonstrator was successfully demonstrated in field tests at China Lake, Calif. The solid state system uses electronic steering to maintain average peak power density and spot size uniformity across all ranges. Efforts are on-going to obtain approvals to allow use of the skid-plate in demonstrations engaging human targets. A skid-plate prototype suitable for demonstrations and assessments is planned for FY17.





The **Mini- Distributed Sound and Light Array (Mini-DSLAs)**, photos above, depicting both day and night capabilities, is a non-lethal acoustic and optical device designed for long range hailing and warning of vehicle and vessel operators.

The Mini-DSLAs prototype uses the combined effects of two integrated sensory stimulators: a distributed, high-output, phased acoustic array and a high-output, coherent (laser) and non-coherent (bright white light) optical array.

The result is an unambiguous signaling capability with multiple mission applications, both land and maritime, including: humanitarian assistance/disaster relief, vehicle/vessel hail/warn, clearing structures and facilities, checkpoint/convoy security, crowd management, forward operating bases and area security, maritime stability operations, defense support to civil authorities and detainee operations.

In 2014, Mini-DSLAs was demonstrated safely and effectively in multiple military exercises, including Exercise Balikatan in the Philippines and the Maritime Military Utility Assessment at Joint Base Langley-Eustis, Virginia.

For additional information on the DoD Non-Lethal Weapons Program, visit:

<http://jnlwp.defense.gov>





Understanding
emerging threats.

Delivering
unbiased expertise.

Advancing
directed energy solutions.

US defense organizations recognize that directed energy (DE) systems may offer advantages that complement traditional kinetic weapons in combatting new threats from our adversaries. Booz Allen Hamilton is delivering expertise to enable and accelerate the development and fielding of new DE solutions to support the warfighter. Our dedicated team of subject matter experts provides comprehensive DE functional and domain expertise throughout the entire life cycle to advance directed energy systems from concept to reality. For more than 100 years, Booz Allen has delivered innovation to solve complex challenges. Our journey towards true DE mission impact has only just begun. See our ideas in action at boozallen.com

Booz | Allen | Hamilton

delivering results that endure

Use of the DoD image does not constitute or imply endorsement.



The Potential Impact of Directed Energy

As threats posed by potential state and non-state adversaries grow in complexity and number while defense budgets are increasingly constrained, the accelerated development, validation, production, fielding, and sustainment of operational directed energy (DE) systems offer the opportunity for the US military to retain its freedom of action and create cost-exchange ratios that favor the United States. In combination with kinetic capabilities, DE technologies can be a significant part of the military's new offset strategy to counter adversary capabilities and impose costs on future enemies.

DE Functional and Domain Expertise

Booz Allen's DE functional and domain expertise supports Navy, Air Force, and the Defense Advanced Research Projects Agency and includes:

- DE weapon effects and threat assessments
- High energy laser (HEL) and high power microwave (HPM) system design, development and testing
- Beam control, acquisition, tracking / pointing and atmospheric compensation (including modeling)
- All aspects of power and thermal management
- Infrared (IR), electro-optical (EO), and radiofrequency (RF) sensors, seekers and countermeasures
- Acquisition program development and management
- Weapon systems design, development, integration, prototyping and test
- Modeling and mission effectiveness
- Operations, training, safety, environmental and bio/health
- Life cycle management

Booz Allen's Full Life Cycle DE Support Role

Booz Allen's expertise and presence across the entire DE acquisition life cycle uniquely positions us to be an **unbiased, trusted agent**, providing objective advice and solutions with **no organizational conflicts of interest**. Our DE-related expertise includes policy support to Office of the Secretary of Defense, technology support for the Navy, Air Force Research Lab and Defense Advanced Research Projects Agency (DARPA), requirements support for AF Product Centers and Air Combat Command and development support for the Army and Navy.

Committed to Advancing DE Solutions

Booz Allen has established a DE Center of Excellence to enable us to be the authoritative, trusted source for knowledge, analysis, expertise, and solutions to accelerate the development, validation, production, fielding, and sustainment of operational DE systems. We are fostering dialogue and interaction among all DE stakeholders to identify threats DE technologies can potentially address; operational advantages of DE capabilities; the potential to transition technologies to programs of record; and technical, funding, cultural, and other barriers to developing and fielding new DE applications. We are united with our clients in a relentless pursuit to deliver new value by solving our nation's toughest problems. Our journey towards true DE mission impact has only just begun.

Booz | Allen | Hamilton

delivering results that endure

Use of the DoD image does not constitute or imply endorsement.

ATA

Applied Technology Associates

BEAM CONTROL STABILIZATION

Beam control stabilization for high energy laser (HEL) systems is critical to meeting system performance requirements. ATA has developed a broad range of custom fast steering mirrors and optical inertial reference units for HEL applications, bringing new meaning to the word "fast," that enable real time corrections in adaptive optics for **directed energy systems**, long range dynamic laser communications, and telescopes. We can build designs using any mirror technology from metal and glass to silicon carbide to meet specific program requirements. ATA's custom fast steering mirrors have ranged from 1-inch high performance laser communications mirrors to proven 12-inch mirrors operating at 1 kHz and higher for directed energy systems. Optical Inertial Reference Units (IRUs) are at the heart of modern acquisition, tracking and pointing (ATP) systems, and ATA has over 30 years of experience solving the most challenging ATP problems through hardware and controls innovations. ATA develops and implements enabling component and system technology for both air and space programs such as the Airborne Laser, the Wide-Band Angular Vibration Experiment, Geostationary Operational Environmental Satellites, Advanced Land Observing Satellite, Lunar Laser Communications Demonstration and the Laser Relay Communications Demonstration. ATA's unique combination of practical experience and patented component technologies are at the core of the best performing family of optical IRUs in the world today.



Artist Rendering of Airborne Laser

SYSTEM TRADES

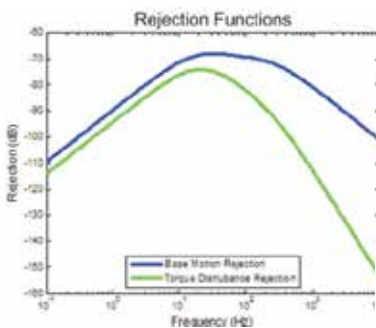

BASE MOTION REJECTION

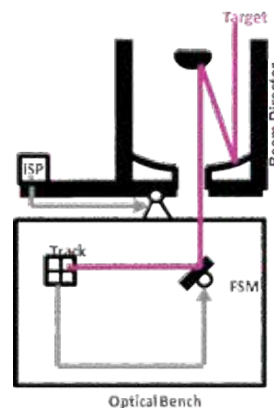
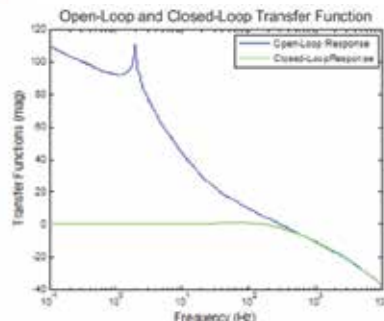

POINTING STABILIZATION CONCEPTS

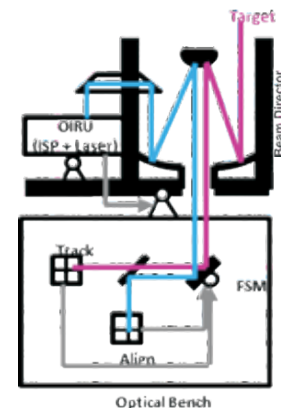

ATA

Applied Technology Associates

BEAM CONTROL STABILIZATION

CONCEPT DESIGN AND BUILD

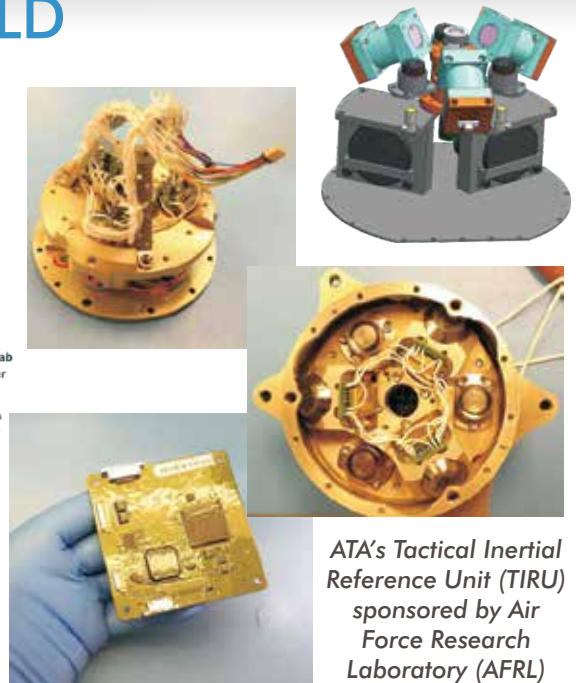
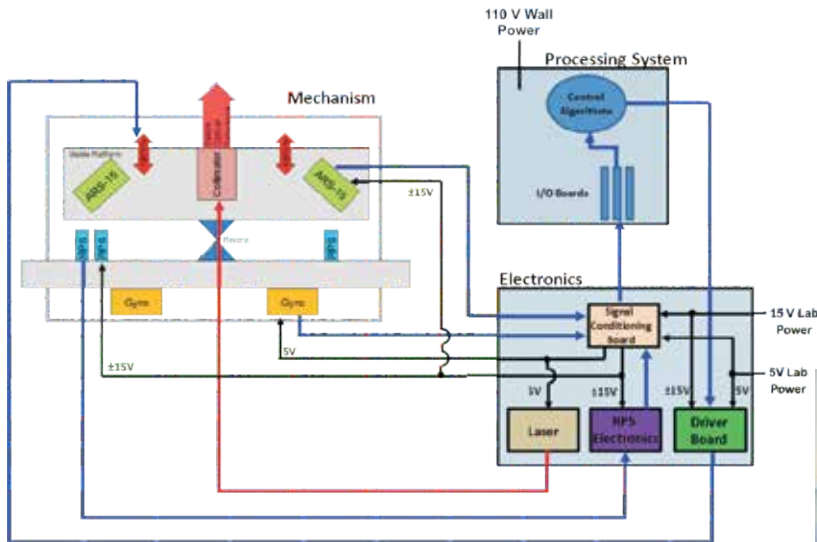

ATA's Tactical Inertial Reference Unit (TIRU) sponsored by Air Force Research Laboratory (AFRL)

ATA develops and manufactures custom sensors, actuators, flexures and controls. ATA produces the highest efficiency actuators available, including space-qualified actuators with redundant core windings. New ATA-designed non-contact linear displacement sensors are capable of the lowest noise floors and sub-nanometer resolution over 1 mm and longer travel, and beveled edges to match mirror rotations. ATA makes the most sensitive, lowest noise angular rate sensors available anywhere, with angular motion measurement capabilities below 40 nanoradians, 1 to 1000 Hz. Combine these capabilities with our 30-year history of excellence in real-time control system development for precision sensing, measurement and control and you have a product line that simply beats the competition. ATA develops and manufactures stabilized platforms and inertial reference units, which can be combined with fast steering mirrors to meet the most stringent system requirements.

PERFORMANCE TEST AND VERIFICATION

Raw, Coh & Noise Spectra

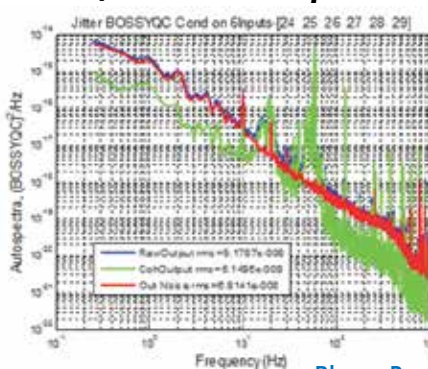

Raw, Coh & Noise Backsums

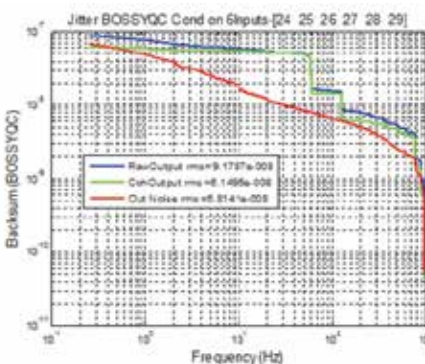

QUIESCENT JITTER

Blue - Raw Scorer Signal
 Green - Coherent with Vibrations
 Red - IRU Jitter (Residual)

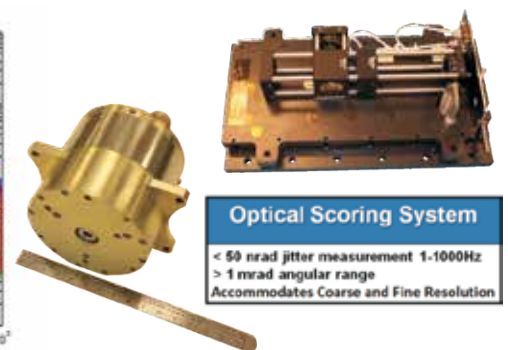

Optical Scoring System
 < 50 nrad jitter measurement 1-1000Hz
 > 1 mrad angular range
 Accommodates Coarse and Fine Resolution

WWW.ATACORP.COM

High-Power Microwave (HPM) Ground-Based Counter Improvised Explosive Device (IED) Pre-Detonation

FORWARD THINKING IN THE PREVENTION OF EXPLOSIVES



The Leidos HPM ground-based counter-IED technology is an unprecedented, first-of-its-kind solution to the standoff, pre-detonation of explosive hazards.

The system, designed for route clearance, convoy, and security control, has been tested in both OCONUS and CONUS environments and is proven to protect warfighters from exposure to blast and shrapnel.

The system also performs successful pre-detonation of a varied set of explosive hazards encountered in combat situations.

ABOUT THE PROGRAM

The Leidos HPM Ground-Based Counter-IED program was developed by the Air Force Research Laboratory's Directed Energy Directorate (AFRL/RD). A strategic partnership has been created between AFRL and the U.S. Army Armament Research and Development and Engineering Center (ARDEC) for future development and transition purposes.

SENSORS, VEHICLE-BORNE EXPLOSIVES, SOURCE AND SYSTEM TECHNOLOGY.



PRIME POWER SUBSYSTEM

- ▶ First-ever mobile megawatt (MW) class direct-drive generator turbine
- ▶ Produces 1.2 MW of power at 22,000 RPM



POWER MODULATION SYSTEM

- ▶ Conditions high-voltage (HV) signal from Prime Power to supply Transmitter Power



TRANSMITTER

- ▶ Phase-locks 8 commercial magnetrons
- ▶ AFRL-patented design
- ▶ Delivers high peak power to the antenna subsystem

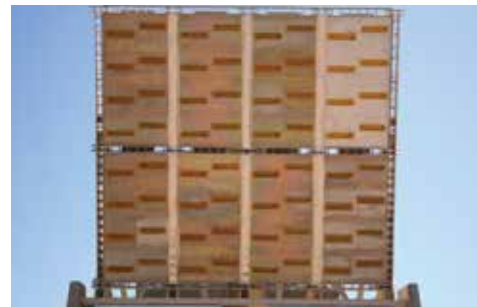

ANTENNA

- ▶ High-gain, planar array antenna
- ▶ High effective radiated power
- ▶ Beam width ~9' (width of vehicle)

FOR MORE INFORMATION:

Fred Rahmer
Program Manager
(O) 505.842.7843
(C) 505.228.9916
Frederick.a.rahmer@leidos.com

Visit us online: leidos.com/natsec



BAE SYSTEMS IS A LEADER IN THE DEVELOPMENT OF ADVANCED TECHNOLOGIES FOR OUR MILITARY.

Currently, we are participating in five key technology areas:

- Office of Naval Research (ONR) Electromagnetic Railgun Innovative Naval Prototype
- Tactical Laser System (TLS)
- High Powered Radio Frequency (HPRF) Naval Weapon System
- High Powered Radio Frequency (HPRF) C-IED Vehicle Weapon System
- Hybrid Electric Drive (HED)



www.baesystems.com

BAE SYSTEMS

INSPIRED WORK

MISSION: POSSIBLE



High-Performance Gen IV *nukW* Fiber Laser Amplifiers

- Kilowatt Class Power at Narrow Linewidth
- Near Diffraction Limited Beam Quality
- High Electrical to Optical Efficiency
- Size, Weight and Power (SWAP) Optimized
- Scalable Architecture



www.nufern.com / 860-408-5000

CONTACT INFORMATION

Mark Neice

DEPS Executive Director

7770 Jefferson NE, Suite 440

Albuquerque, NM 87109

505-998-4910

mark@deps.org

Cynthia Kaiser, DE Outreach

HEL JTO / DEPS Coordinator

7770 Jefferson NE, Suite 440

Albuquerque, NM 87109

505-249-9117

cynthia@stsincalb.com

